



TOMOE TRITEC

THE ULTIMATE PROCESS VALVE

150 / 300 / 600 / 900 / 1500 / 2500LB RANGE

TOMOE TRITEC LTD.

Single Offset

The centre of rotation is moved back from the centreline of the valve disc. The seat and seal are designed conically and on centre. This design relies on a frictional, interference seal and so is applicable only to soft seated valves.

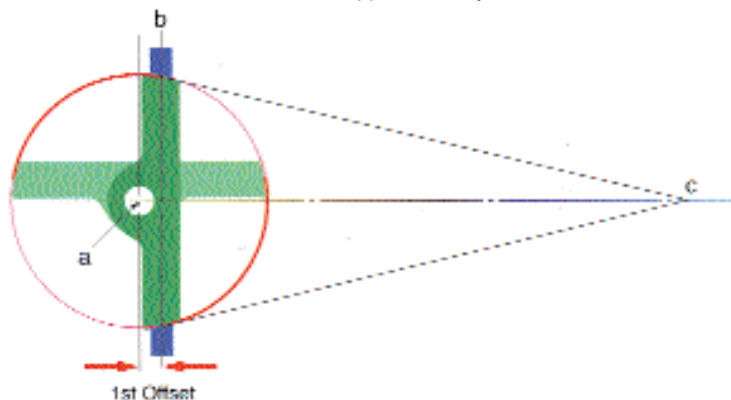

Double Offset

The centre of rotation is moved from the centerline of the valve body. The seat and seal design remains conical and on centre. This design again relies on a frictional, interference seal, but the length of rotation over which this friction occurs is reduced, allowing a larger range of process resistant seat materials to be used. However these materials must be relatively soft or highly elastic to prevent “jamming”.

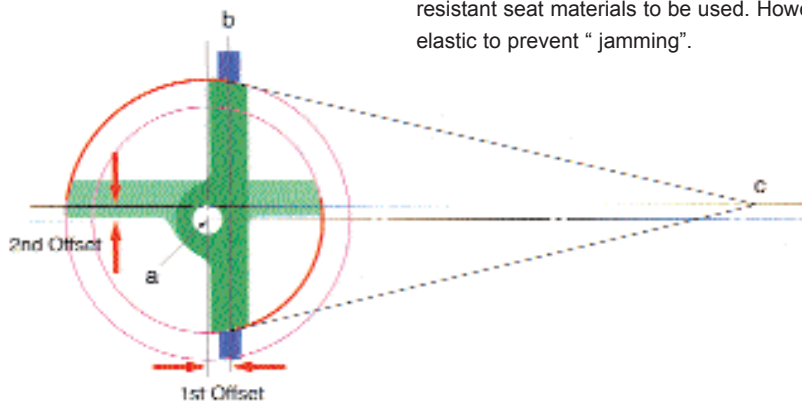

Triple Offset

The centreline of the cone is rotated away from the valve centreline resulting in an ellipsoidal profile and providing the third offset. With this geometry, seat seal interference is completely eliminated ensuring long sealing life. The result is a torque seated, process pressure aided FRICTIONLESS seal. The geometry allows the body seat to be used as the closed limit stop, aiding operator adjustment. The Triple Offset design is ideally suited to metal seated valves providing bubble-tight performance on high temperature, high pressure and firesafe applications.

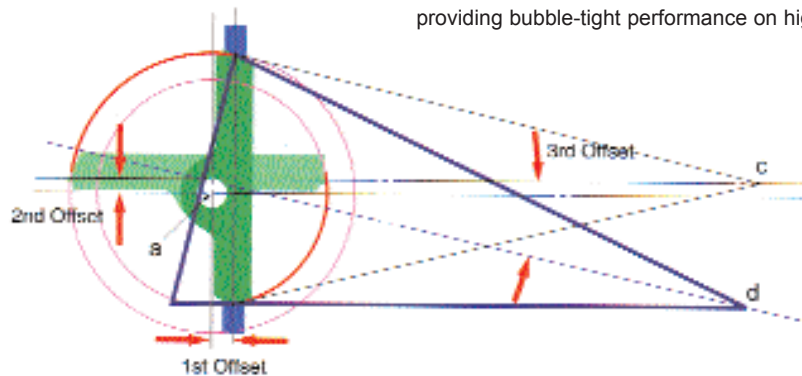

Offset Valve-Disc/Seat Friction

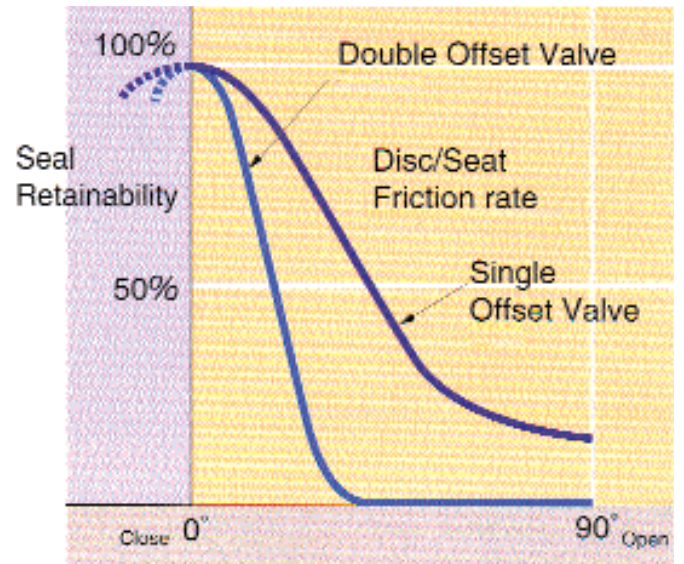
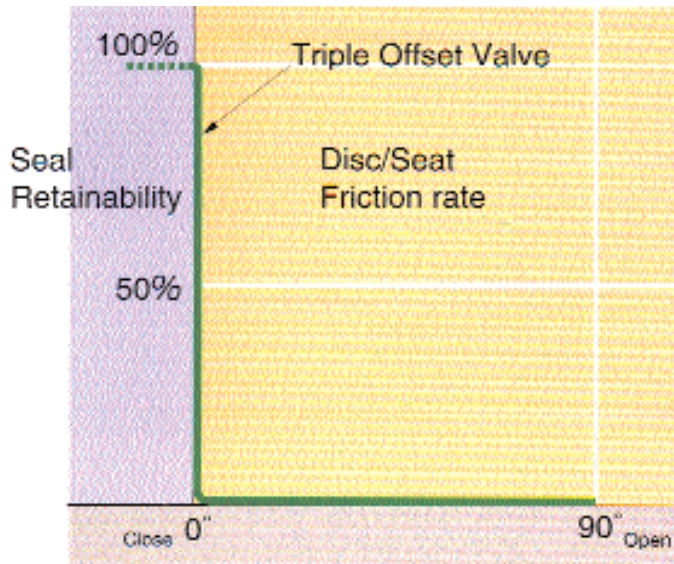

Features of the Tritec Valve

- Triple offset and ellipsoidal sealing geometry
- Bi-directional zero leakage
- Inherently Firesafe
- Developed Geometry results in
 - Zero Seat/Seal Friction
 - Low Torques
 - Extended Service Life
 - Continued Seal through Thermal Cycling
 - Torque Seating

- Excellent flow and throttling characteristics covering services from Cryogenic to high temperature
 - Excellent control of Fugitive Emission by virtue of Rotary stem movement and advanced packing materials
 - Less than 10ppm on Fugitive Emission Test to cover EPA21
- Other tests available on request*

- Firesafe to BS6755 part 2 / API 6FA and API Std 607 4th Edition



- Available Fully Rated to Class 1500Lb

- Fully rated for end of line duty

- Standard materials conform to NACE, all exotic materials also available.

- Laminated seat is mounted in the body, removing it from the erosive effects of the flowing media

- Seat is self centering "floating" design

- Both Seat and Seal are field replaceable without special tools.

- Unique elliptical bolting pattern allows foolproof replacement of seat and seal

- Gasket Sealing Face is completely uninterrupted by fixings

- Suitable for use with Spiral Wound gaskets and all flange finishes including RTJ

- Antiblowout device on shaft with both internal and external retaining systems according to API Std 609

- ISO mounting flange allows easy fitting and changing of operators

- Operator is bolted and doweled to prevent radial movement and subsequent loss of seating torque.

- Body counterbore and seat bolting arranged elliptically to ensure equal support, gasket land and gasket loading all around the elliptical edge of the laminated body seat.

- Inboard AND outboard thrust mechanisms prevent decentralising of disc, even under high temperature and line pressure.

- By eliminating seat-seal friction on unseating, Tritec removes the "Blind Zone" and increases the rangeability or controllable range to the full 90° of movement. The rotation geometry and inboard bearing design reduce the effect of dynamic torque and mechanical noise-vibration, increasing midrange control accuracy. Cavitation and Noise reducers are available to complement the Tritec valve under high pressure drop process situations.

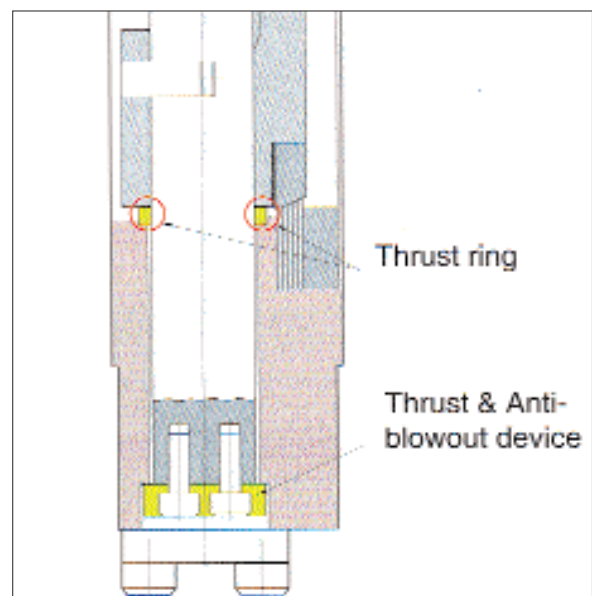
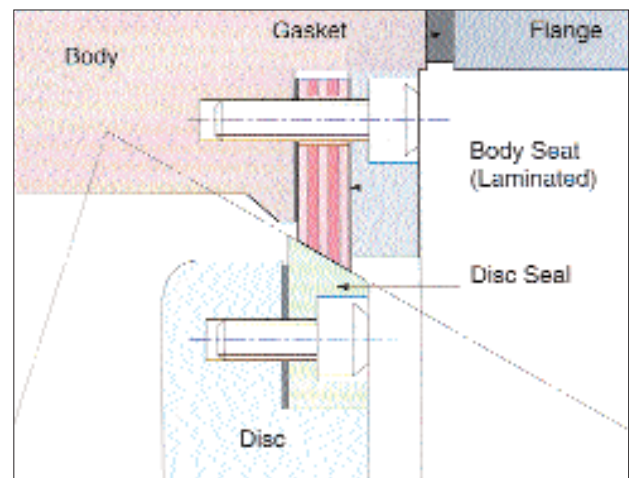

■ **CRYSEAL - CRYOGENIC VALVES.** Temperatures to - 196°C. Designed, tested and certified to BS6364 1988.



■ **DOUBLE BLOCK & BLEED VALVES.** To allow verifiable, maintainable shut-off in critical isolation applications. Firetested to BS 6755 part 2/API6FA & API607 4th edition.

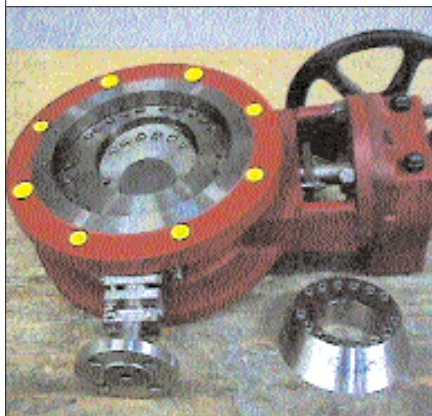

■ **STEAM JACKETED VALVES.** To maintain process temperatures ensuring media remains fluid. Disc and shaft steam tracing as an option.



■ **TOP ENTRY VALVES**
Allowing complete maintainability on valves which are welded into line. Available on standard and cryogenic ranges.

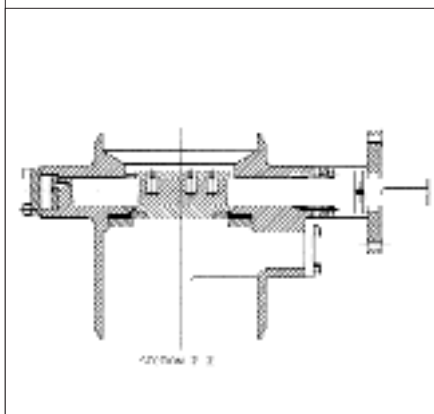

■ **CONTROL VALVES.** Frictionless seating means increased rangeability, allowing the Tritec valve to perform in both control and isolation application



■ **VALVES TO REDUCE FUGITIVE EMISSION.** Designed to reduce fugitive emission, testing is available to all international standards plus customer specific requirements.



■ **COMMISSIONING SETS**
Allowing process flow rates to be set accurately via manually operated valves.

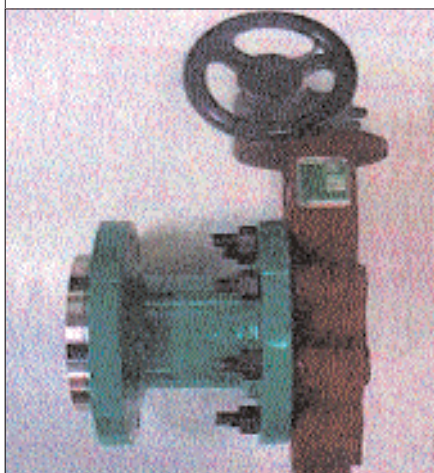

■ **TADPOLE RUBBER SEALED VALVES.** Resilient sealed, double offset valves available in ratings to 300LB, in all materials and with various seal rubbers. eg Nitrile, Viton, EPDM, Silicon, Butyl etc

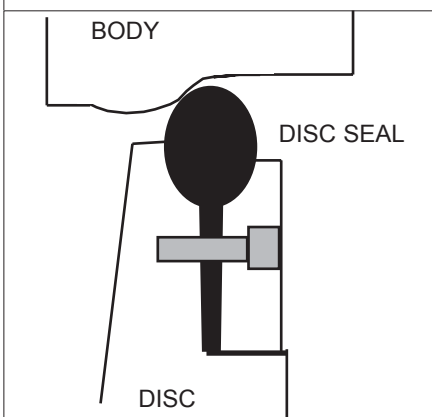

■ **RUBBER SEALED VALVES.** Extending the range of materials available in the Tomoe Rubber seated valve range.

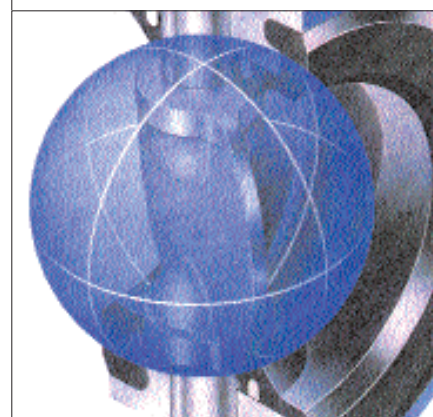

Standard Specifications

Design	API Std 609, BS 5155, ANSI B16.34, ASME SEC VIII
Valve Sizes	2"(50mm) - 48"(1200mm)
Pressure Classes	Class 150Lb - Class 1500Lb
Body Styles	Lugged, Wafer Flangeless, Double Flanged, Butt Weld End
Flange Accommodation	ANSI B16.5: 2" - 24" ANSI B16.47 Series A&B : 26" - 48"
Face to Face Dimensions	LUG and WAFER Type API Std 609 Table 2 : 3" - 24" API Std 609 Table 1 : 30", 36", 42", 48" SO 5752 Wafer Short : 28", 32", 40" DOUBLE FLANGED Type ISO 5752/BS 5155 Double Flange Short
Pressure Temperature Ratings	ASME/ANSI B16.34 : for Steel ASME/ANSI B16.24 : for Bronze Working Temperature Range as Standard -29°C (-20°F) to +538°C (1000°F) With selection of suitable materials -100°C (-148°F) to +700°C (1292°F)
Pressure Tests	Shell Test, Seat Test API Std 598 Seat Leakage Rate API Std 598, ISO 5208 Rate A, ANSI B16.104 (ANSI / FCI 70-2) Class VI
Firesafe	Certified Firesafe to BS 6755 Part2/API 6FA and API 607 4th Ed.
Marking	API Std 609 MSS SP-25
Operators	Manual, Electric, Pneumatic, Hydraulic

- * 1. Please contact the sales office for larger sizes.
- * 2. Please contact the sales office for pressure classes above 1500Lb.
- * 3. JIS 10K, 20K, 30K MSS, API, BS, DIN, PN, ISO also available on request.
- * 4. ISO 5752 Gate Valve Short (Basic series 3/ASME B16.10) on request.
- * 5. For Cryogenic range (temperature to -196°C (-320°F)), please contact the sales office.

ITEM	DESCRIPTION	STANDARD General hydrocarbon duties including Sour Gas, Flare Gas, Steam and Process Gases.	OPTION 1 Low temperature hydrocarbons (down to -100°C), Condensates Blowdown Gas and other general corrosive duties.
1	Body	Cast carbon steel ASTM A216 WCB or Plate carbon steel ASTM A516 Gr.70 or BS EN10025 S275JR	Cast Stainless steel ASTM A351 CF8M
2	Disc	Cast carbon steel ASTM A216 WCB	Cast Stainless steel ASTM A351 CF8M
★ 3	Body Seat	Laminated Stainless steel type 316/Graphite	Laminated steel type 316/Graphite
4	Body Seat Retaining Ring	Steel	Stainless steel type 316
★ 5	Body Seat Gasket	Graphite	Graphite
6	Disc Seal	Stainless steel type 316	Stainless steel type 316
7	Disc Seal Gasket	Graphite	Graphite
8	Shaft	Stainless steel ASTM A564 type 630 H1150+1150	Stainless steel ASTM A564 type 630 H1150+1150
9	Shaft Pin	Stainless steel ASTM A564 type 630 H1150+1150	Stainless steel ASTM A564 type 630 H1150+1150
10	Bearing	Stainless steel type 316/hard chrome plated	Stainless steel type 316/hard chrome plated
11	Thrust Ring	Stainless steel type 316/hard chrome plated	Stainless steel type 316/hard chrome plated
12	Thrust Pad	Stainless steel ASTM A564 type 630 H1150+1150	Stainless steel ASTM A564 type 630 H1150+1150
13	End Cover	Stainless steel type 316	Stainless steel type 316
14	End Cover Gasket	Graphite	Graphite
15	Gland Plate	Stainless steel type 316	Stainless steel type 316
16	Gland Plate Spigot	Stainless steel type 316	Stainless steel type 316
17	Mounting Plate	Steel	Steel
18	Dowel Pin	Stainless steel type 316	Stainless steel type 316
19	Nameplate	Stainless steel type 316	Stainless steel type 316
22	Disc Seal Screw	Stainless steel type 316	Stainless steel type 316
23	Thrust Pad Screw	Stainless steel type 316	Stainless steel type 316
24	Body Seat Screw	Stainless steel type 316	Stainless steel type 316
25	Mounting Plate Screw	Stainless steel type 316	Stainless steel type 316
26	End Cover Screw	Stainless steel type 316	Stainless steel type 316
27	Gland Stud	Stainless steel type 316	Stainless steel type 316
29	Gland Nut	Stainless steel type 316	Stainless steel type 316
★ 33	Gland Packing	Graphite Passivated	Graphite passivated
★ 34	Gland Packing	Braided Graphite	Braided Graphite
35	Operator Key	Steel	Steel
37	Anti-blowout Collar	Stainless steel type 316	Stainless steel type 316
38	Set Screw Anti-blowout	Stainless steel type 316	Stainless steel type 316

★ Recommended Spares

The materials shown above are representative, all other materials and surface treatments are available on request, eg. Incoloy, Titanium, Monel, Hastelloy, Inconel, Stellite, Titanium Nitride.

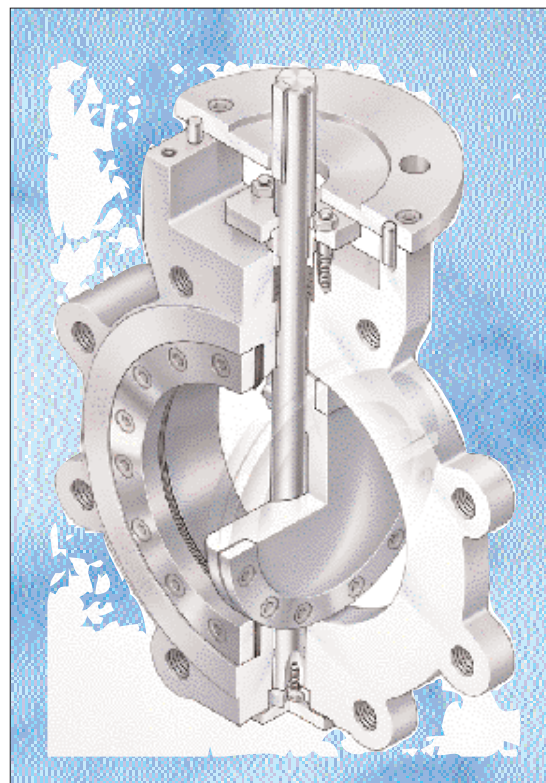
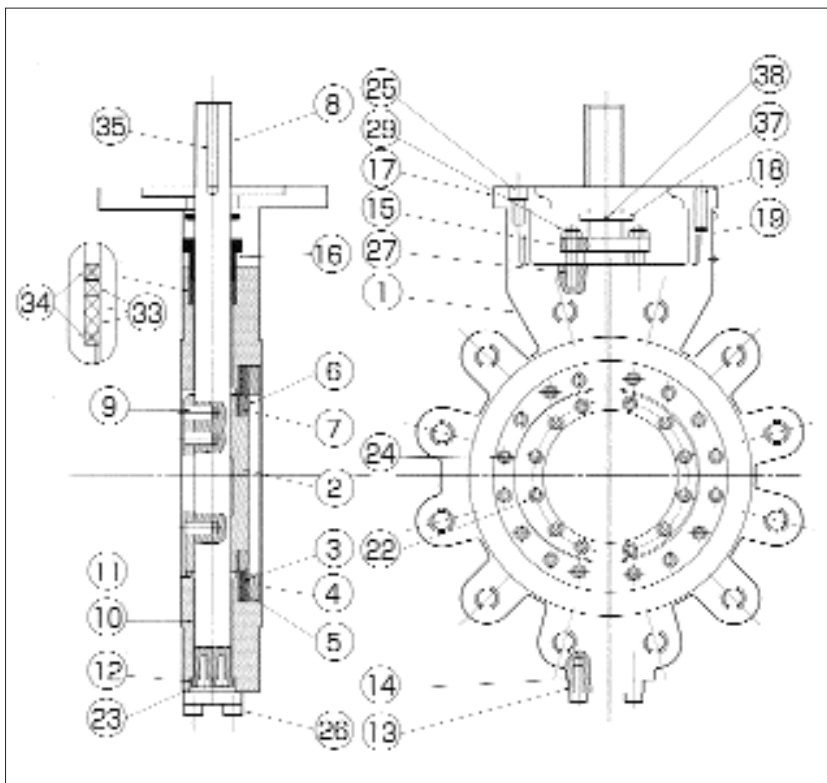

OPTION 2 High chloride duties, eg. Sea water and Fire water, Low temperature and sour hydrocarbons.	OPTION 3 Very high chloride duties, eg. Brine and Acids, Sour hydrocarbons and other corrosive duties.	OPTION 4 Sea water, Fire water, Cooling water and Deluge systems.
Cast Super Duplex Stainless steel ASTM A890 Grade 6A	Cast 6Mo Stainless steel ASTM A351 CK3-MCuN	Cast Nickel Aluminium Bronze BS 1400 AB2
Cast Super Duplex Stainless steel ASTM A890 Grade 6A	Cast 6Mo Stainless steel ASTM A351 CK3-MCuN	Cast Nickel Aluminium Bronze BS 1400 AB2
Laminated Super Duplex Stainless steel UNS S32760 / Graphite	Laminated Super Duplex Stainless steel UNS S32760 / Graphite	Laminated Monel 400/Graphite
Super Duplex Stainless steel UNS S32760	Super Duplex Stainless steel UNS S32760	Cast Nickel Aluminium Bronze BS 1400 AB2
Graphite	Graphite	Graphite
Super Duplex Stainless steel UNS S32760	Super Duplex Stainless steel UNS S32760	Cast Nickel Aluminium Bronze BS 1400 AB2
Graphite	Graphite	Graphite
Super Duplex Stainless steel UNS S32760	Super Duplex Stainless steel UNS S32760	Monel K500
Super Duplex Stainless steel UNS S32760	Super Duplex Stainless steel UNS S32760	Monel K500
Stainless steel type 316/hard chrome plated	Stainless steel type 316/hard chrome plated	Stainless steel type 316/hard chrome plated
Stainless steel type 316/hard chrome plated	Stainless steel type 316/hard chrome plated	Stainless steel type 316/hard chrome plated
Super Duplex Stainless steel UNS S32760	Super Duplex Stainless steel UNS S32760	Monel K500
Super Duplex Stainless steel UNS S32760	Super Duplex Stainless steel UNS S32760	Cast Nickel Aluminium Bronze BS 1400 AB2
Graphite	Graphite	Graphite
Stainless steel type 316	Stainless steel type 316	Stainless steel type 316
Stainless steel type 316	Stainless steel type 316	Stainless steel type 316
Steel	Steel	Steel
Stainless steel type 316	Stainless steel type 316	Stainless steel type 316
Stainless steel type 316	Stainless steel type 316	Stainless steel type 316
Super Duplex Stainless steel UNS S32760	Super Duplex Stainless steel UNS S32760	Monel K500
Super Duplex Stainless steel UNS S32760	Super Duplex Stainless steel UNS S32760	Monel K500
Super Duplex Stainless steel UNS S32760	Super Duplex Stainless steel UNS S32760	Monel K500
Stainless steel type 316	Stainless steel type 316	Stainless steel type 316
Stainless steel type 316	Stainless steel type 316	Stainless steel type 316
Stainless steel type 316	Stainless steel type 316	Stainless steel type 316
Stainless steel type 316	Stainless steel type 316	Stainless steel type 316
Graphite passivated	Graphite passivated	Graphite passivated
Braided Graphite	Braided Graphite	Braided Graphite
Steel	Steel	Steel
Stainless steel type 316	Stainless steel type 316	Stainless steel type 316
Stainless steel type 316	Stainless steel type 316	Stainless steel type 316

Pressure - Temperature Ratings

Body A216 Gr. WCB
 Disc A216 Gr. WCB
 Shaft A564 type 630

Body A351 Gr. CF8M
 Disc A351 Gr. CF8M
 Shaft A564 type 630

Temperature		Working Pressure (MPa)	
(°F)	(°C)	Class 150	Class 300
-20	-29	1.96	5.10
100	38	1.96	5.10
200	93	1.79	4.65
300	149	1.59	4.52
400	204	1.38	4.38
500	260	1.17	4.14
600	316	0.965	3.79
650	343	0.862	3.69
700	371	0.758	3.69
750	399	0.655	3.48
800	427	0.552	2.83
850	454	0.448*	1.86*
900	482	0.345*	1.17*
950	510	0.241*	0.724*
1000	538	0.138*	0.345*

Temperature		Working Pressure (MPa)	
(°F)	(°C)	Class 150	Class 300
-20	-29	1.90	4.96
100	38	1.90	4.96
200	93	1.62	4.27
300	149	1.48	3.86
400	204	1.34	3.55
500	260	1.17	3.31
600	316	0.965	3.10
650	343	0.862	3.07
700	371	0.758	2.96
750	399	0.655	2.93
800	427	0.552	2.90
850	454	0.448	2.90
900	482	0.345	2.86
950	510	0.241	2.65
1000	538	0.138	2.41

(Notes)

* Permissible, but not recommended for prolonged use above 800°F (427°C).

Please contact the sales office for temperatures outside of standard temperature range as detailed in the above table.

Body A216 Gr. WCB
 Disc A216 Gr. WCB
 Shaft A564 type 630

Body A351 Gr. CF8M
 Disc A351 Gr. CF8M
 Shaft A564 type 630

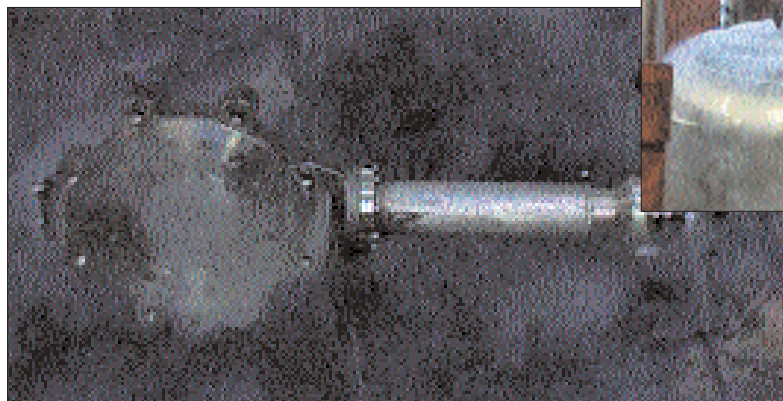
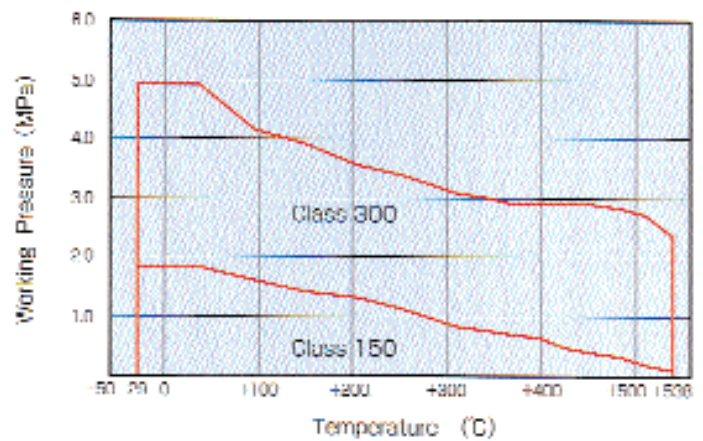
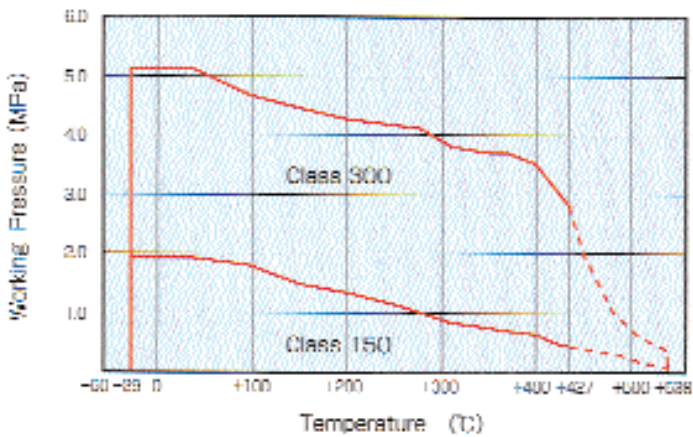

150Lb

Valve size		5°	10°	15°	20°	25°	30°	35°	40°	45°	50°	55°	60°	65°	70°	75°	80°	85°	90°
mm	inch																		
80	3	1	6	14	23	31	39	47	54	62	71	82	96	112	128	143	156	163	165
100	4	2	12	26	42	57	72	85	98	113	130	150	176	205	234	262	285	299	302
150	6	16	31	45	59	76	101	134	178	233	297	369	448	531	616	698	758	796	796
200	8	30	57	82	108	140	185	246	327	427	544	676	821	974	1130	1280	1390	1460	1460
250	10	52	99	142	187	242	320	426	566	739	942	1170	1420	1690	1960	2220	2410	2530	2530
300	12	78	147	212	279	362	478	636	846	1100	1410	1750	2120	2520	2920	3310	3600	3780	3780
350	14	106	201	289	380	493	651	866	1150	1500	1920	2380	2890	3430	3980	4510	4890	5140	5140
400	16	165	313	451	594	769	1020	1350	1800	2350	2990	3720	4510	5350	6210	7040	7640	8020	8020
450	18	217	413	594	782	1010	1340	1780	2370	3090	3940	4890	5940	7050	8180	9270	10100	10600	10600
500	20	268	509	733	965	1250	1650	2200	2920	3820	4860	6040	7340	8710	10100	11400	12400	13000	13000
600	24	386	734	1060	1390	1800	2380	3170	4210	5500	7000	8700	10600	12500	14500	16500	17900	18800	18800
700	28	559	1060	1530	2010	2610	3450	4590	6100	7960	10100	12600	15300	18200	21100	23900	25900	27200	27200
750	30	630	1200	1720	2270	2940	3880	5160	6870	8960	11400	14200	17200	20400	23700	28900	29200	30700	30700
800	32	719	1370	1970	2590	3360	4440	5900	7840	10200	13000	16200	19700	23300	27100	30700	33300	35000	35000
900	36	884	1680	2420	3180	4120	5450	7250	9630	12600	16000	19900	24200	28700	33300	37700	40900	43000	43000
1000	40	1170	2220	3190	4210	5450	7210	9580	12700	16600	21200	26300	31900	37900	44000	49800	54100	56900	56900
1050	42	1230	2340	3370	4440	5760	7610	10100	13400	17600	22400	27800	33700	40000	46500	52600	57100	60000	60000
1200	48	1640	3120	4490	5920	7670	10100	13500	17900	23400	29800	37000	45000	53400	61900	70100	76100	80000	80000

300Lb

Valve size		5°	10°	15°	20°	25°	30°	35°	40°	45°	50°	55°	60°	65°	70°	75°	80°	85°	90°
mm	inch																		
80	3	1	6	14	23	31	39	47	54	62	71	82	96	112	128	143	156	163	165
100	4	2	12	26	42	57	72	85	98	113	130	150	176	205	234	262	285	299	302
150	6	6	25	41	54	69	91	121	162	212	268	334	407	482	559	634	689	725	725
200	8	11	45	74	98	126	166	222	298	389	492	613	746	884	1030	1160	1260	1330	1330
250	10	19	82	135	178	229	301	402	540	705	891	1110	1350	1600	1860	2110	2290	2410	2410
300	12	29	122	202	266	342	450	601	807	1050	1330	1660	2020	2400	2780	3150	3420	3600	3600
350	14	39	167	274	363	466	613	818	1100	1430	1810	2260	2750	3260	3780	4290	4660	4900	4900
400	16	58	248	408	539	692	910	1220	1630	2130	2690	3360	4090	4840	5610	6370	6920	7280	7280
450	18	77	326	537	710	911	1200	1600	2150	2810	3550	4420	5380	6380	7400	8390	9110	9590	9590
500	20	95	403	663	876	1130	1480	1980	2650	3460	4380	5460	6640	7880	9130	10400	11300	11800	11800
600	24	136	580	955	1260	1620	2130	2850	3820	4990	6310	7860	9570	11300	13100	14900	16200	17100	17100
700	28	199	844	1390	1840	2360	3100	4150	5560	7260	9190	11400	13900	16500	19100	21700	23600	24800	24800
750	30	232	986	1620	2150	2750	3620	4840	6490	8480	10700	13400	16300	19300	22400	25400	27500	29000	29000
800	32	261	1110	1830	2420	3100	4080	5450	7310	9550	12100	15000	18300	21700	25200	28600	31000	32600	32600
900	36	332	1410	2320	3070	3940	5190	6930	9300	12100	15400	19100	23300	27600	32000	36300	39400	41500	41500
1000	40	399	1700	2790	3690	4740	6230	8330	11200	14600	18400	23000	28000	33200	38400	43600	47400	49900	49900
1050	42	457	1940	3200	4230	5430	7140	9540	12800	16700	21100	26300	32000	38000	44000	50000	54200	57100	57100
1200	48	480	2040	3360	4440	5700	7500	10000	13400	17500	22200	27700	33700	39900	46300	52500	57000	60000	60000

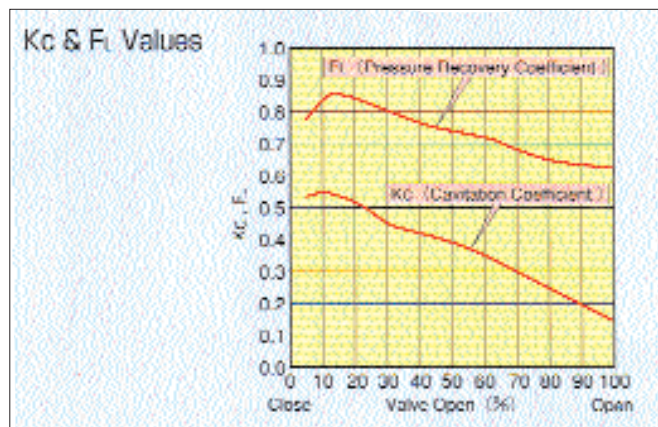
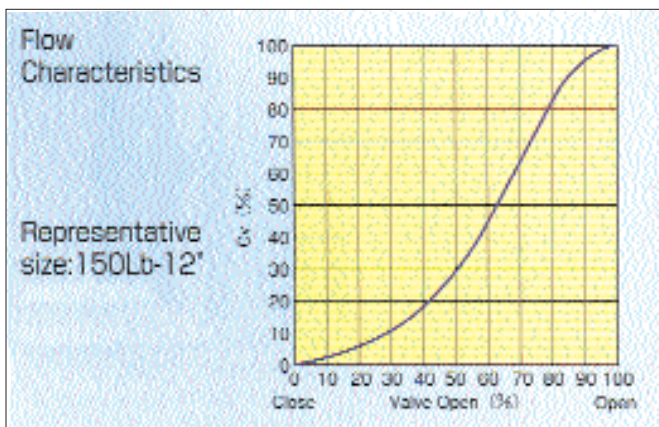

* Contact the sales office for Cv and sizing information if not shown here.

Valve Operating Torques (Nm)

VALVE SIZE	CLASS 150Lb (20 BAR G)				MAXIMUM SHAFT TORQUE	MINIMUM SIZING DP (BAR)
	PREFERRED DIRECTION		REVERSE DIRECTION			
	OPENING	SEATING	OPENING	SEATING		
2	60	50	35	70	142	20
3	90	80	50	120	335	20
4	120	110	70	150	660	20
5	130	120	80	190	881	20
6	150	140	90	260	881	20
8	350	260	105	445	881	20
10	600	500	300	900	1607	20
12	960	800	400	1200	2677	20
14	1400	1200	600	1600	3517	15
16	2000	1800	850	2700	7421	10
18	2900	1900	1050	3650	7421	10
20	3785	2400	1600	4500	11479	10
24	6535	3240	2760	7100	22453	10
28	11818	6500	4368	13942	28015	5
30	18481	7618	5409	20689	30332	5
32	19405	8537	6583	21359	41829	5
36	27504	13779	8810	32473	50133	5
40	36034	17928	11180	42782	59520	5
42	37524	20118	14081	43561	81853	5
48	60027	28565	20997	67595	102734	5

VALVE SIZE	CLASS 300Lb (52 BAR G)				MAXIMUM SHAFT TORQUE	MINIMUM SIZING DP (BAR)
	PREFERRED DIRECTION		REVERSE DIRECTION			
	OPENING	SEATING	OPENING	SEATING		
2	90	75	55	105	142	35
3	150	135	75	250	335	35
4	200	170	105	320	660	35
5	270	240	120	420	881	35
6	390	350	200	570	1260	35
8	960	700	395	1270	2677	30
10	1500	1100	710	1800	4165	30
12	2650	1600	1320	2900	7421	30
14	3720	1900	1840	3750	11529	30
16	5920	3730	2940	6710	17590	20
18	9000	4600	4200	9420	28015	15
20	11440	5670	5560	11600	34357	15
24	19100	8500	9340	18140	50313	10

VALVE SIZE	CLASS 600Lb (100 BAR G)				MAXIMUM SHAFT TORQUE
	PREFERRED DIRECTION		REVERSE DIRECTION		
	OPENING	SEATING	OPENING	SEATING	
3	220	161	43	338	484
4	371	325	84	612	883
6	896	729	269	1356	2240
8	1817	1315	1156	2471	5309
10	3384	2397	1538	4243	10369
12	4667	3146	2232	5581	13802
14	7310	4200	3520	7990	22781
16	10238	6995	4954	12279	34996
18	16426	10170	8696	17900	60474
20	20504	12995	11805	21694	71123
24	36276	20412	22550	36276	126164

Valve Operating Torques (Nm)

VALVE SIZE	CLASS 900Lb (150 BAR G)				MAXIMUM SHAFT TORQUE
	PREFERRED DIRECTION		REVERSE DIRECTION		
	OPENING	SEATING	OPENING	SEATING	
3	334	240	70	504	664
4	652	96	142	1006	1296
6	1535	1098	467	2166	3557
8	2831	1961	1108	3684	7559
10	5960	3595	2751	6804	17918
12	9071	4741	4233	9579	28454
14	21205	6260	6456	12105	42473
16	16735	10425	8860	18300	60474
18	26640	15158	15120	26678	96031
20	36115	19429	21299	36115	126164
24	59910	30421	39453	59910	204101

VALVE SIZE	CLASS 1500Lb (255 BAR G)				MAXIMUM SHAFT TORQUE
	PREFERRED DIRECTION		REVERSE DIRECTION		
	OPENING	SEATING	OPENING	SEATING	
6	4122	2777	1060	5839	7559
8	6514	4206	1914	8806	11664
10	10456	6040	3485	13011	22782
12	14490	8998	6210	17278	34997
14	25563	12490	9657	28396	50945
16	35832	25304	14930	46206	82955
18	52837	34268	22354	64751	110413
20	73771	44903	33532	85142	162022
24	119434	63957	61643	121748	339785

- Contact the sales office for torque figures not shown above.
- Torques shown are for full rating and are linear with pressure. Do not use less than the minimum sizing DP when calculating operating torques.
- Tomoe Tritec suggests a minimum of 20% Safety Factor on the above torques.
- Although the valves are suitable for Bi-Directional use, the offset geometry creates a Preferred direction of flow which if used (for uni-directional flow) can show a torque and actuator size reduction.
- Maximum shaft torque is for 17-4PH in the H1150+1150 condition. For other shaft materials, consult Tomoe Tritec for guidance.
- Run torques are 40% of the Preferred direction Opening torque.
- Torques shown are valid for temperatures of -100°C (-148°F) to +538°C (+1000°F) For temperatures outside this range consult Tomoe Tritec.
- Torques shown assume a maximum liquid velocity (pipeline) of 5 m/s. For higher liquid velocity, where hydrodynamic torque may need to be considered, consult Tomoe Tritec.
- Please ensure that any actuator chosen to operate the Tritec valve is capable of supplying 5° over-travel and has mechanical limit stops controlling the closed position.
- Note that operators must be dowelled to the valve mounting plate. Dowels will be supplied with bareshaft valves but it is the purchasers responsibility to ensure separately purchased operators and mounting kits are machined to accommodate these dowels.
- If in doubt, contact the sales office.

TORQUE CONVERSION FACTORS				
N m	kN m	kgf m	lbf in	lbf ft
1	0.001	0.102	8.85	0.738
1000	1	101.972	8851	737.6
9.807	.0098	1	86.8	7.233
0.113	1.13 x 10 ⁻⁴	0.01155	1	0.083
1.356	0.0014	0.138	12	1

Allowable Seat Leakage Rates by Standard (Gas Test)

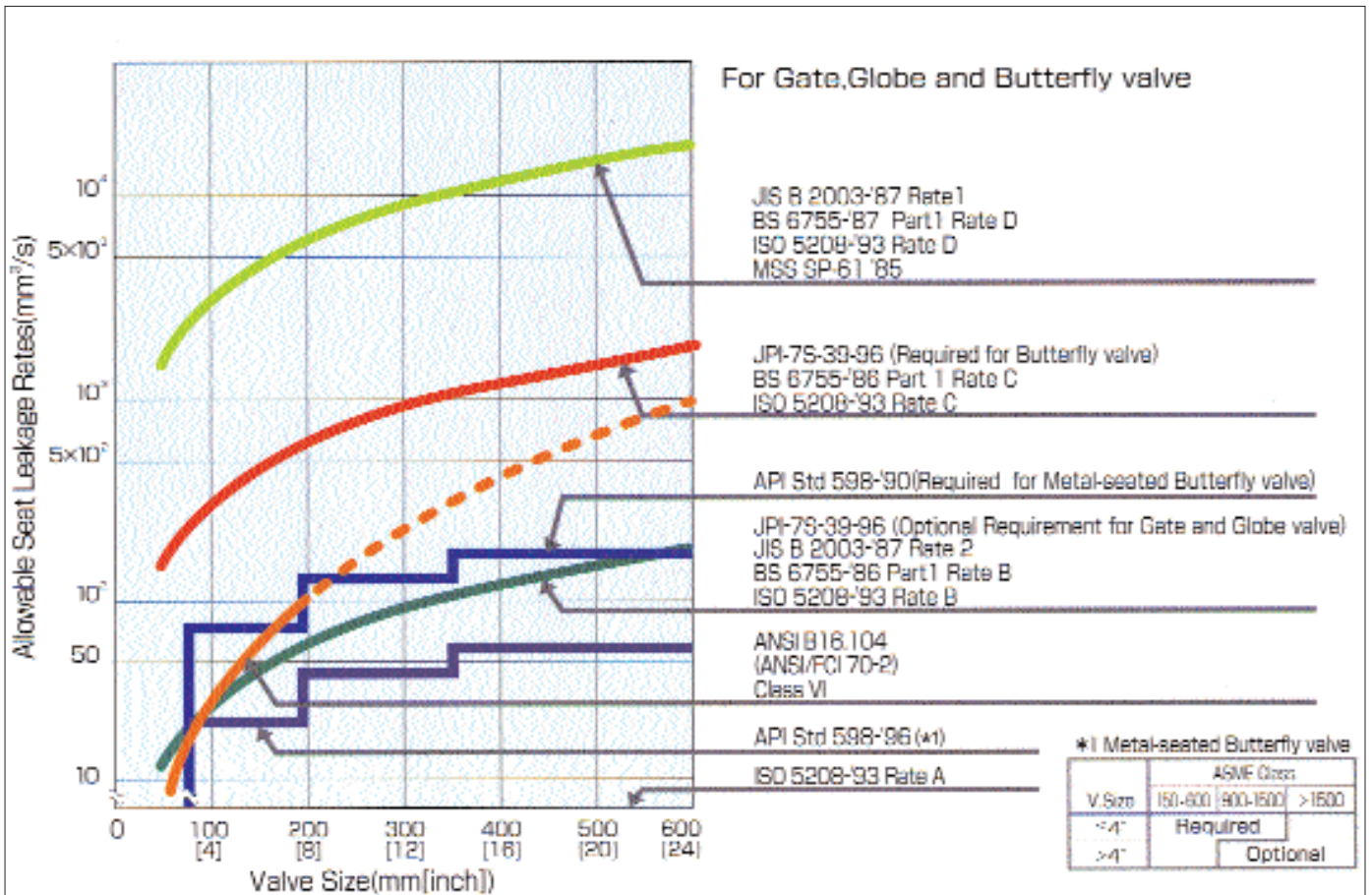

Allowable Seat Leakage Rates by Standard (Gas Test)

REFERENCE

Valve size : 200mm (cc/min converted)

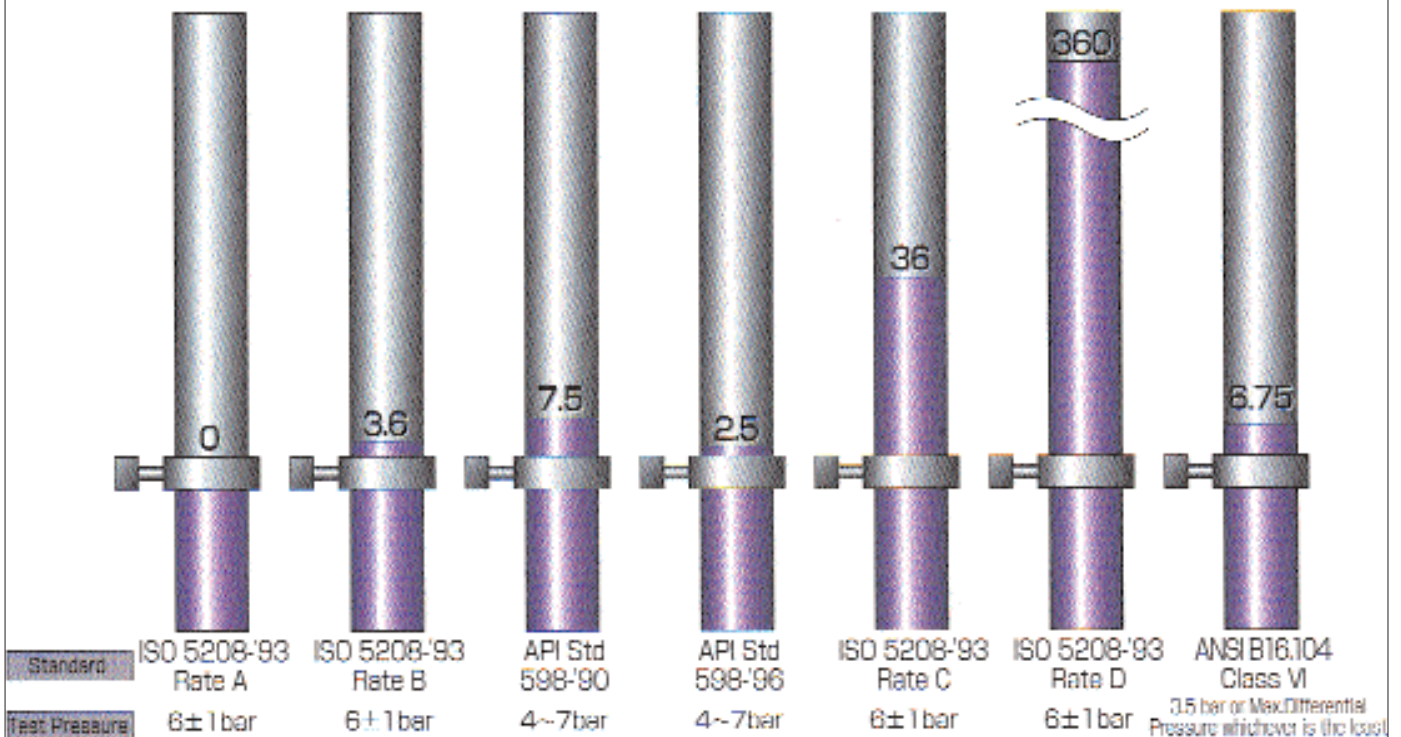

Allowable Seat Leakage Rates by Standard (Liquid Test)

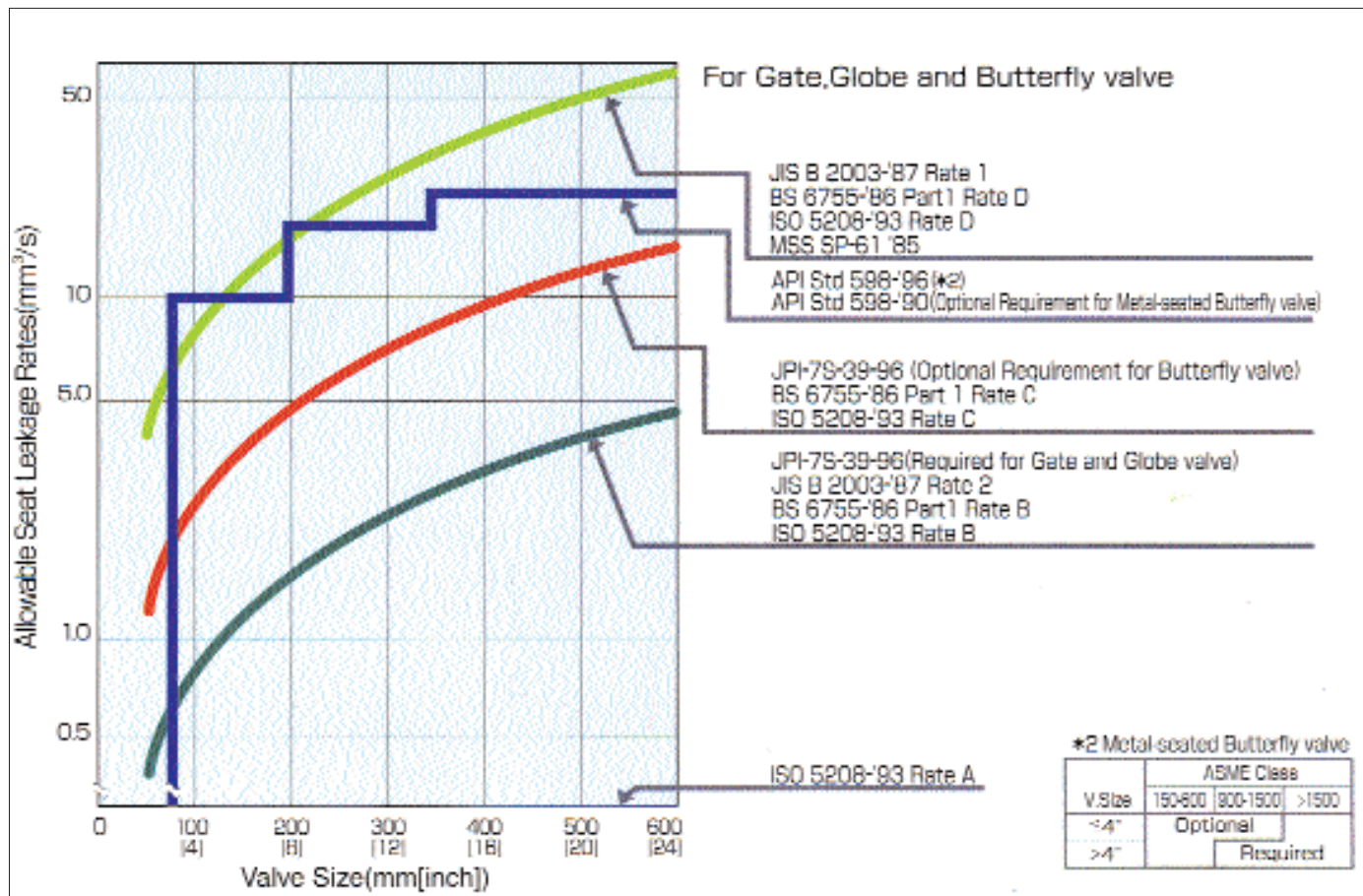

Allowable Seat Leakage Rates by Standard (Liquid Test)

REFERENCE

Valve size : 200mm (cc/min converted)

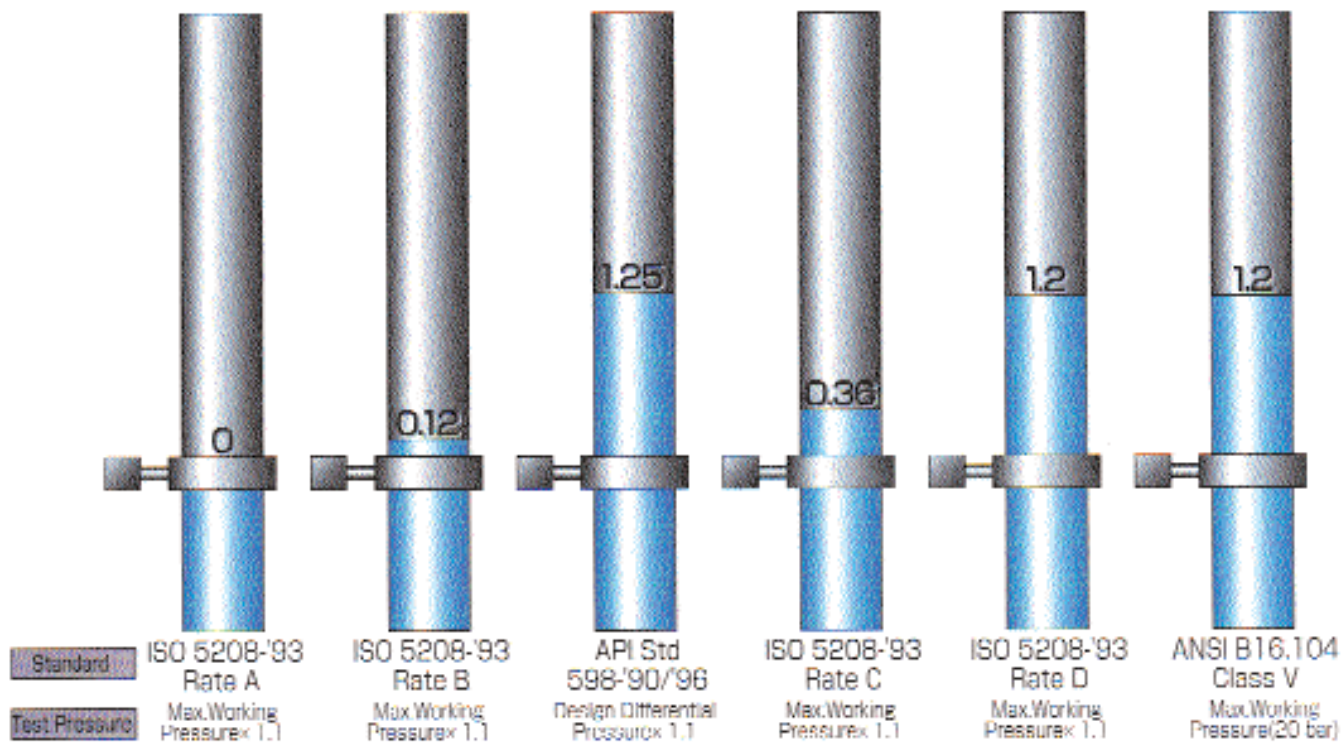

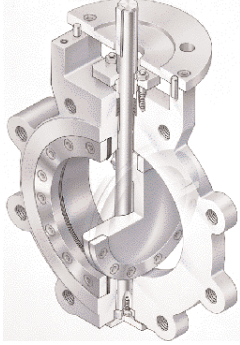
COMPARISON BY VALVE TYPES	TOMOE TRITEC	GATE VALVE
		
TEMPERATURE RANGE	-196° to +700°C	-196° to +700°C
MAX. PRESSURE CLASS	CLASS 1500LB	CLASS 2500LB
BODY CONNECTION	WAFER, LUGGED, DOUBLE FLANGED, BUTT WELD END	DOUBLE FLANGED WELDED
WEIGHT	SMALL	LARGE
SPACE	SMALL	LARGE
SEAT SEALING PERFORMANCE	TIGHT SHUT OFF	CLASS IV or TIGHT SHUT OFF (depending on seat material)
SEAT SEAL FRICTION	NONE	HIGH
SEALING LIFE	VERY GOOD	DISADVANTAGEOUS
STEM MOVEMENT	ROTARY QUARTER TURN	LINEAR MULTI-TURN
EMISSION SEAL PERFORMANCE	GOOD	DISADVANTAGEOUS
INHERENTLY FIRESAFE	YES	YES
FIRETESTED	YES	AVAILABLE
GEOMETRY OFFSET	TRIPLE	N/A
THRUST BEARINGS	YES(2)	N/A
ONE PIECE SHAFT	YES	N/A
EASE OF MAINTENANCE	EXCELLENT	DISADVANTAGEOUS
FLOW CAPACITY Cv	25d ²	45d ²
RANGEABILITY	50 to 100 : 1	N/A
FLOW CHARACTERISTIC	EQUAL PERCENT	QUICK OPENING TO LINEAR
RECOVERY COEFFICIENT FL	0.85	N/A
CAVITATION COEFFICIENT Kc	0.32	N/A
OPERATOR COST	LOW low torque + quarter turn	HIGH multi turn motor
COSTS		
MATERIAL	LOW	HIGH above 300 mm
FREIGHT	LOW	HIGH
INSTALLATION	LOW	HIGH
PIPE SUPPORT	LOW	HIGH

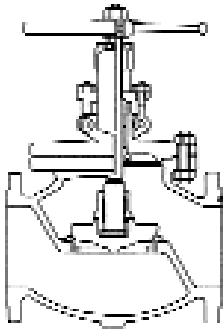
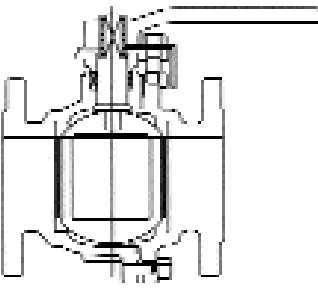
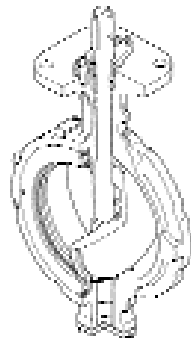
GLOBE VALVE	BALL VALVE	TYPICAL HPBV
		
-196°C to +650°C	-196°C to +700°C	-50°C to +250°C
CLASS 600LB	CLASS 2500LB	CLASS 300LB
SCREWED, WELDED DOUBLE FLANGED	DOUBLE FLANGED WELDED	WAFER, LUGGED
LARGE	LARGE	SMALL
LARGE	LARGE	SMALL
CLASS IV or TIGHT SHUT OFF (depending on seat material)	CLASS IV or TIGHT SHUT OFF (depending on seat material)	CLASS IV or TIGHT SHUT OFF (depending on seat material)
YES	HIGH	YES
DISADVANTAGEOUS	DISADVANTAGEOUS	GOOD
LINEAR MULTI-TURN	ROTARY QUARTER TURN	ROTARY QUARTER TURN
DISADVANTAGEOUS	GOOD	GOOD
METAL SEATED YES	METAL SEATED YES	METAL SEATED YES
AVAILABLE	AVAILABLE	AVAILABLE
N/A	CONCENTRIC	DOUBLE
N/A	YES	YES
N/A	NO	YES
DISADVANTAGEOUS	DISADVANTAGEOUS	GOOD
15d ²	45d ²	30d ²
50 to 100 : 1	50 : 1	30 : 1
VARIOUS AVAILABLE	EQUAL PERCENT	EQUAL PERCENT
0.85	0.55	0.74
0.65	0.22	0.38
HIGH multi turn motor	HIGH torque typically 2X TOMOE TRITEC	LOW low torque + quarter turn
HIGH	HIGH above 150 mm	LOW
HIGH	HIGH	LOW
HIGH	HIGH	LOW
HIGH	HIGH	LOW

<NOTE> GATE, GLOBE and BALL valve properties are typical, not specific to any manufacturer.

N/A : Not applicable

150Lb

Valve size		H ₁	H ₂	A	L ₁	L			Approx.weight (Kg)*		
mm	inch					Lugged Type	Wafer Type	Flanged Type	Lugged Type	Wafer Type	Flanged Type
50	2	107	152	34	22	43	43	108	7	7	13
80	3	127	159	34	29	48	48	114	9	9	16
100	4	151	194	34	31	54	54	127	17	15	24
150	6	177	242	34	37	57	57	140	26	24	40
200	8	195	237	34	41	64	64	152	35	30	57
250	10	227	277	64	46	71	71	165	55	46	92
300	12	266	325	79	53	81	81	178	95	87	155
350	14	293	352	79	61	92	92	190	135	120	197
400	16	336	425	79	64	102	102	216	189	163	272
450	18	356	443	79	75	114	114	222	256	229	297
500	20	391	482	79	81	127	127	229	300	273	428
600	24	463	550	109	97	154	154	267	543	483	674
700	28	567	661	129	104	165	165	292	740	660	875
750	30	597	676	129	102	165	165	318	927	773	1125
800	32	627	722	129	117	190	190	318	1080	948	1245
900	36	687	795	175	125	200	200	330	1628	1305	1725
1000	40	716	815	175	135	216	216	410	1945	1556	2292
1050	42	746	850	175	153	251	251	410	2240	1892	2501
1200	48	840	995	199	162	276	276	470	2787	2459	3440

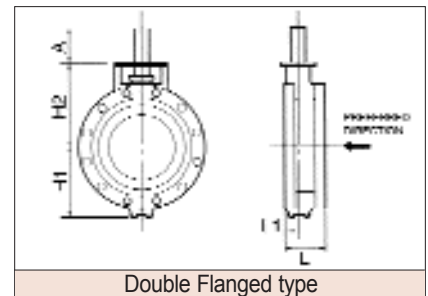
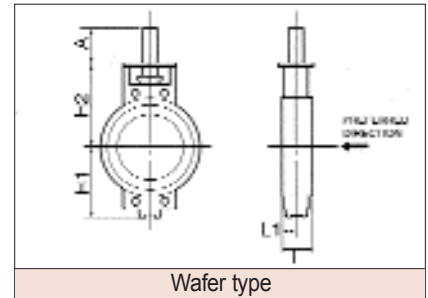
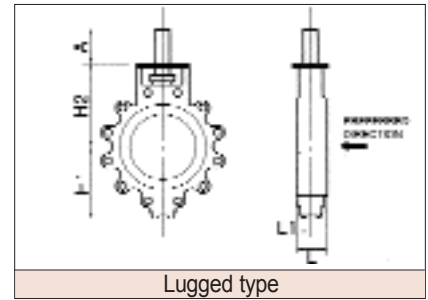

150Lb Manual gear type

Valve size		B	C	D	øW	Approx. weight (Kg)*
mm	inch					
50	2	179	152	31	125	10
80	3	186	152	39	125	12
100	4	221	152	39	125	20
150	6	269	152	39	125	29
200	8	272	184	52	254	40
250	10	319	230	67	356	63
300	12	375	279	90	457	110
350	14	402	314	90	610	150
400	16	475	391	154	610	230
450	18	497	498	60	610	313
500	20	548	498	60	610	361
600	24	615	530	97	610	606
700	28	736	617	237	610	920
750	30	828	685	237	457	1107
800	32	874	685	237	457	1260
900	36	969	758	292	610	1908
1000	40	989	758	292	610	2225
1050	42	1024	758	292	610	2520
1200	48	1113	1065	356	762	3497

150Lb Allowable Min. Internal Diameter for Piping

Valve size		øS ₁	øS ₂
mm	inch		
80	3	73	61
100	4	89	82
150	6	131	122
200	8	184	178
250	10	228	220
300	12	282	273
350	14	315	303
400	16	372	339
450	18	401	385
500	20	462	431
600	24	564	510
700	28	660	646
750	30	709	698
800	32	756	742
900	36	847	830
1000	40	926	910
1050	42	985	967
1200	48	1192	1098

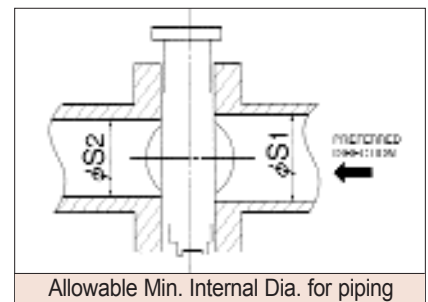
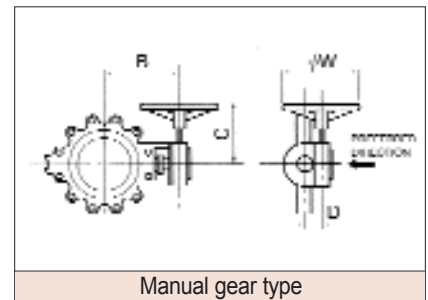

* For valve sizes above 24", dimensions will be identical for both ASME B16.47 Series 'A' and Series 'B'. However the weight given is for the heavier version.(Series'A')

300Lb

Valve size		H ₁	H ₂	A	L ₁	L			Approx. weight (Kg)*		
mm	inch					Lugged Type	Wafer Type	Flanged Type	Lugged Type	Wafer Type	Flanged Type
50	2	107	152	34	22	43	43	108	10	10	17
80	3	127	159	34	29	48	48	114	12	12	19
100	4	151	194	34	31	54	54	127	26	21	39
150	6	199	269	64	37	59	59	140	48	35	86
200	8	218	285	79	44	73	73	152	69	54	107
250	10	251	325	79	48	83	83	165	108	80	136
300	12	296	387	79	54	92	92	178	167	134	229
350	14	331	410	79	61	117	117	190	238	168	314
400	16	377	465	109	67	133	133	216	363	226	413
450	18	407	528	109	79	149	149	222	496	345	525
500	20	440	561	129	85	159	159	229	559	391	667
600	24	512	636	128	97	181	181	267	805	670	957
700	28	640	800	199	104	209	209	292	1363	1193	1335
750	30	690	825	199	117	241	241	318	1658	1463	1715
800	32	720	860	199	117	241	241	318	1856	1661	1957
900	36	780	940	199	130	260	260	330	2511	2281	2590
1000	40	750	910	199	135	300	300	410	2424	2214	2585
1050	42	786	945	199	151	300	300	410	2649	2439	2849
1200	48	850	1000	249	167	320	320	470	3684	3384	4106

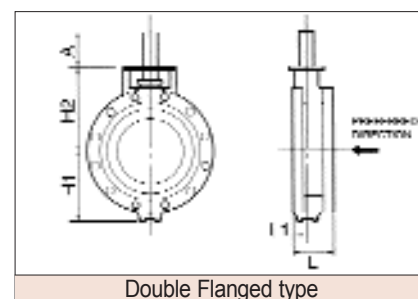
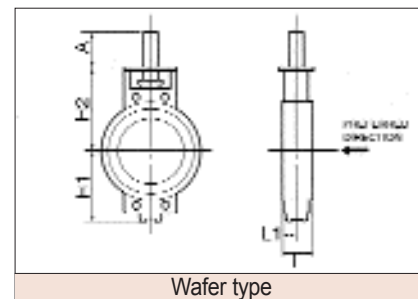
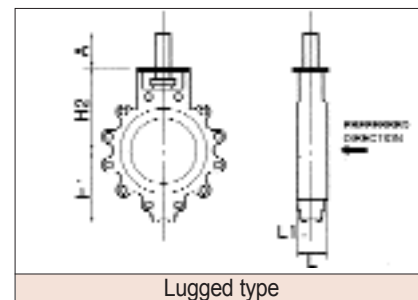

300Lb Manual gear type

Valve size		B	C	D	øW	Approx. weight (Kg)*
mm	inch					
50	2	179	152	31	125	13
80	3	186	152	39	125	15
100	4	229	169	52	200	26
150	6	311	223	67	300	43
200	8	335	279	90	457	68
250	10	375	314	90	610	95
300	12	437	391	154	610	175
350	14	464	498	60	610	209
400	16	531	560	138	457	287
450	18	593	560	181	457	408
500	20	636	582	237	457	571
600	24	789	668	237	356	1000
700	28	974	758	292	610	1640
750	30	999	758	292	610	1935
800	32	978	1029	356	610	2570
900	36	1058	1065	356	762	3225
1000	40	1028	1065	356	762	3140
1050	42	1063	1065	356	762	3365
1200	48	1180	1233	537	762	5400

300Lb Allowable Min. Internal Diameter for Piping

Valve size		øS ₁	øS ₂
mm	inch		
80	3	73	61
100	4	89	82
150	6	130	122
200	8	181	177
250	10	223	219
300	12	278	273
350	14	301	304
400	16	356	337
450	18	386	385
500	20	431	429
600	24	549	510
700	28		
750	30		
800	32		
900	36		
1000	40		
1050	42		
1200	48		

Please contact the sales office.

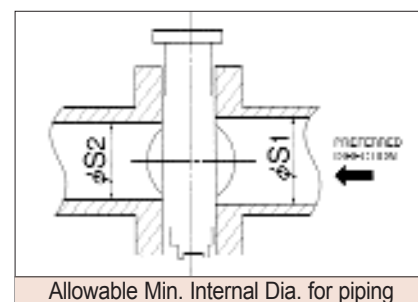
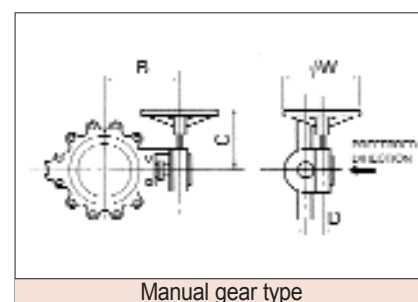

* For valve sizes above 24", dimensions will be identical for both ASME B16.47 Series 'A' and Series 'B'. However the weight given is for the heavier version.(Series'A')

600Lb

Valve size		H1	H2	A	L1	L			Approx.weight (Kg)*		
mm	inch					Lugged Type	Wafer Type	Flanged Type	Lugged Type	Wafer Type	Flanged Type
80	3	154	202	44	31	54	54	180	16	15	43
100	4	166	208	44	35	64	64	190	30	28	69
150	6	238	302	79	43	78	78	210	72	65	135
200	8	248	315	79	60	102	102	230	102	92	162
250	10	316	376	79	66	117	117	250	187	134	268
300	12	349	442	109	76	140	140	270	259	224	369
350	14	374	457	109	85	155	155	290	329	285	364
400	16	474	561	129	102	178	178	310	520	455	632
450	18	476	610	129	112	200	200	330	635	555	739
500	20	504	645	129	112	216	216	350	804	694	879
600	24	555	730	178	127	232	232	390	1243	1093	1423
700	28	Please contact the sales office.									
750	30										
800	32										
900	36										
1000	40										
1050	42										
1200	48										

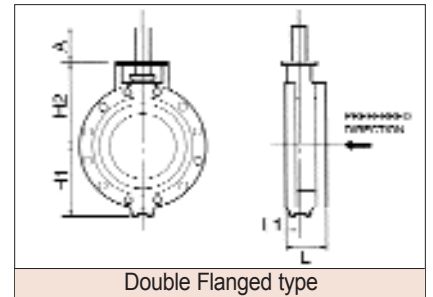
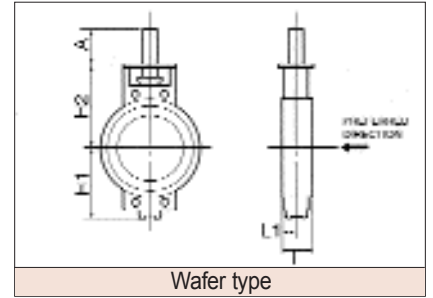
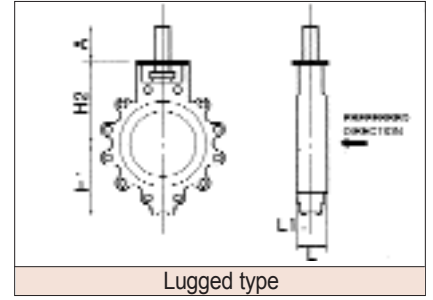

600Lb Manual gear type

Valve size		B	C	D	øW	Approx. weight (Kg)*
mm	inch					
80	3	237	169	52	200	20
100	4	250	207	67	254	39
150	6	352	314	90	610	90
200	8	365	391	154	610	147
250	10	430	463	54	457	247
300	12	508	463	54	457	319
350	14	522	560	181	457	449
400	16	636	582	237	457	701
450	18	762	665	237	356	830
500	20	797	685	237	457	1000
600	24	904	758	292	610	1520
700	28	Please contact the sales office.				
750	30					
800	32					
900	36					
1000	40					
1050	42					
1200	48					

600Lb Allowable Min.Internal Diameter for Piping

Valve size		øS1	øS2
mm	inch		
80	3	51	0
100	4	61	53
150	6	100	97
200	8	149	112
250	10	196	189
300	12	220	216
350	14	253	246
400	16	290	269
450	18	351	334
500	20	385	387
600	24	510	499
700	28	Please contact the sales office.	
750	30		
800	32		
900	36		
1000	40		
1050	42		
1200	48		

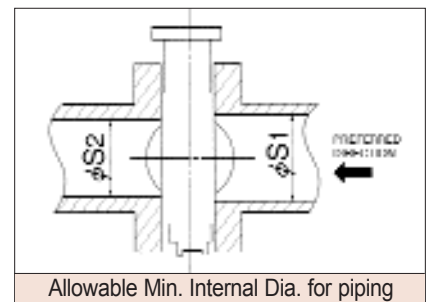
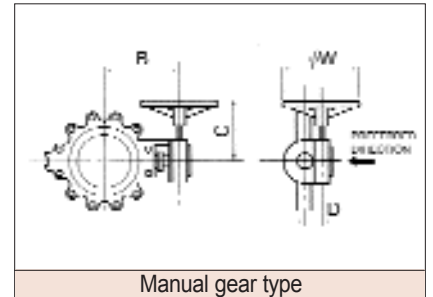

900Lb

Valve size		H ₁	H ₂	A	L ₁	L			Approx. weight (Kg)*		
mm	inch					Lugged Type	Wafer Type	Flanged Type	Lugged Type	Wafer Type	Flanged Type
100	4	181	240	64	40	80	80	235	43	39	93
150	6	238	315	79	52	104	104	250	100	89	184
200	8	281	360	79	60	112	112	310	151	134	256
250	10	358	412	109	71	135	135	350	256	224	425
300	12	383	475	109	85	170	170	380	352	298	496
350	14	419	512	128	88	173	173	400	440	376	656
400	16	455	610	129	107	210	210	430	663	570	834
450	18	503	660	178	114	228	228	460	824	691	1044
500	20	550	685	178	127	250	250	490	1069	905	1273
600	24	656	790	199	142	275	275	530	1704	1317	2506
700	28	Please contact the sales office.									
750	30										
800	32										
900	36										
1000	40										
1050	42										
1200	48										

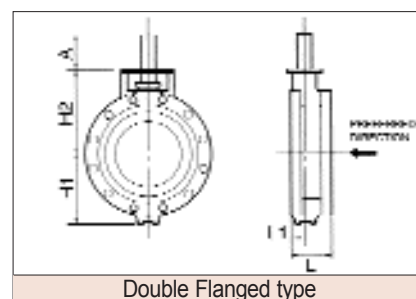
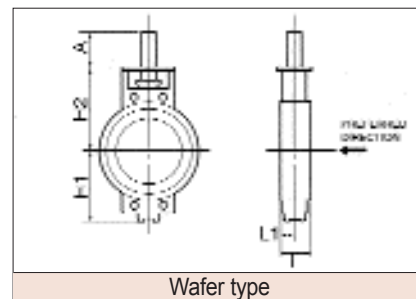
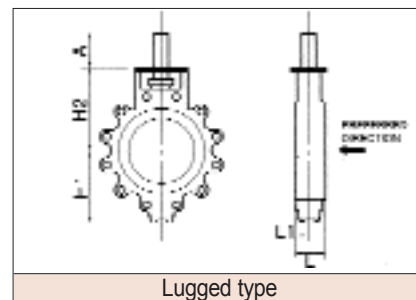

900Lb

Manual gear type

Valve size		B	C	D	øW	Approx. weight (Kg)*
mm	inch					
100	4	290	247	67	365	59
150	6	365	331	123	457	130
200	8	414	498	60	610	212
250	10	478	560	138	457	329
300	12	540	560	181	457	472
350	14	587	582	237	457	621
400	16	762	665	237	356	857
450	18	834	723	292	457	1100
500	20	859	758	292	610	1346
600	24	908	994	356	457	2417
700	28	Please contact the sales office.				
750	30					
800	32					
900	36					
1000	40					
1050	42					
1200	48					

900Lb

Allowable Min. Internal Diameter for Piping

Valve size		øS ₁	øS ₂
mm	inch		
100	4	28	41
150	6	77	80
200	8	136	132
250	10	184	186
300	12	212	209
350	14	239	252
400	16	261	270
450	18	323	334
500	20	376	382
600	24	488	488
700	28	Please contact the sales office.	
750	30		
800	32		
900	36		
1000	40		
1050	42		
1200	48		

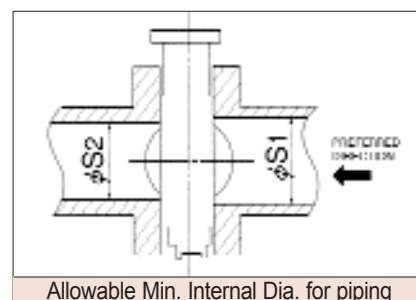
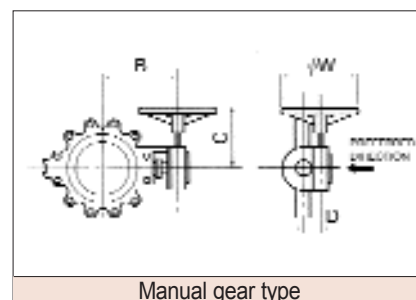

1500Lb

Valve size		H1	H2	A	L1	L			Approx.weight (Kg)*		
mm	inch					Lugged Type	Wafer Type	Flanged Type	Lugged Type	Wafer Type	Flanged Type
150	6	257	347	109	80	160	160	290	175	124	207
200	8	307	405	109	90	180	180	330	237	202	406
250	10	371	510	129	100	200	200	390	379	282	646
300	12	414	545	129	118	230	230	430	605	360	842
350	14	493	610	178	124	250	250	470	849	589	1163
400	16	530	655	199	133	265	265	510	995	614	1476
450	18	591	750	199	154.5	300	300	550	1478	992	1968
500	20	664	810	199	169.5	340	340	630	2248	1597	2782
600	24	780	950	249	204	400	400	710	3021	1792	4288
700	28	Please contact the sales office.									
750	30										
800	32										
900	36										
1000	40										
1050	42										
1200	48										

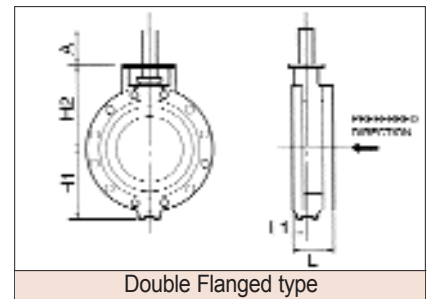
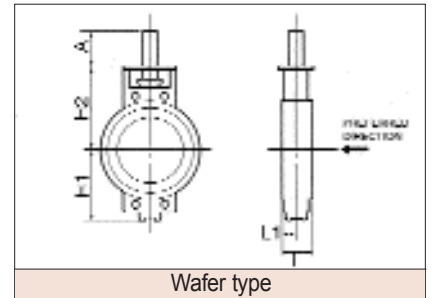
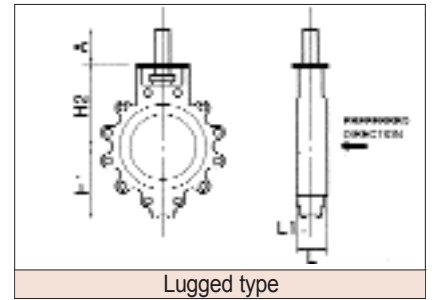

1500Lb Manual gear type

Valve size		B	C	D	øW	Approx. weight (Kg)*
mm	inch					
150	6	413	463	60	457	60
200	8	470	560	181	457	230
250	10	585	582	237	610	181
300	12	697	685	237	457	197
350	14	784	722	292	457	277
400	16	773	1028	356	610	714
450	18	868	1028	356	610	748
500	20	928	1028	356	610	714
600	24	1100	1146	442	610	1164
700	28	Please contact the sales office.				
750	30					
800	32					
900	36					
1000	40					
1050	42					
1200	48					

1500Lb Allowable Min. Internal Diameter for Piping

Valve size		øS1	øS2
mm	inch		
150	6	0	0
200	8	0	11
250	10	67	85
300	12	105	106
350	14	157	134
400	16	209	185
450	18	238	237
500	20	286	257
600	24	315	325
700	28	Please contact the sales office.	
750	30		
800	32		
900	36		
1000	40		
1050	42		
1200	48		

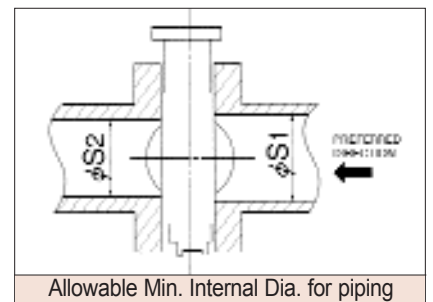
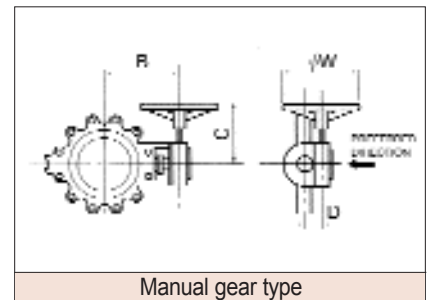

Gate Valve Face to Face

For the direct replacement of gate valves, all dimensions are exactly as per the standard Double Flanged valve with the exception of the face to face dimension which is shown below.
(in accordance with ISO 5752 gate valve short).

Valve size		150LB	300LB	600LB	900LB	1500LB
mm	inch	Flanged Gate F-F	Flanged Gate F-F	Flanged Gate F-F	Flanged Gate F-F	Flanged Gate F-F
50	2	178	216			
80	3	203	282	356		
100	4	229	305	432	457	
150	6	267	403	559	610	705
200	8	292	419	660	838	832
250	10	330	457	787	838	991
300	12	356	502	838	965	1130
350	14	381	762	889	1029	1257
400	16	406	838	991	1130	1384
450	18	432	914	1092	1219	1537
500	20	457	991	1194	1321	1664
600	24	508	1143	1397	1549	1943

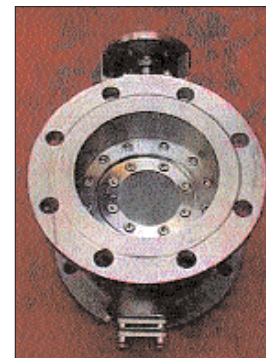

Allows direct replacement of existing gate valves without modification of pipework.

Disc remains within the body face to face in the fully open position to allow removal of the valve from pipework even when the valve is open.

Reduction of fugitive emission due to quarter turn rather than linear shaft movement.

Reduced operator costs due to quarter turn rather than multi turn / linear.

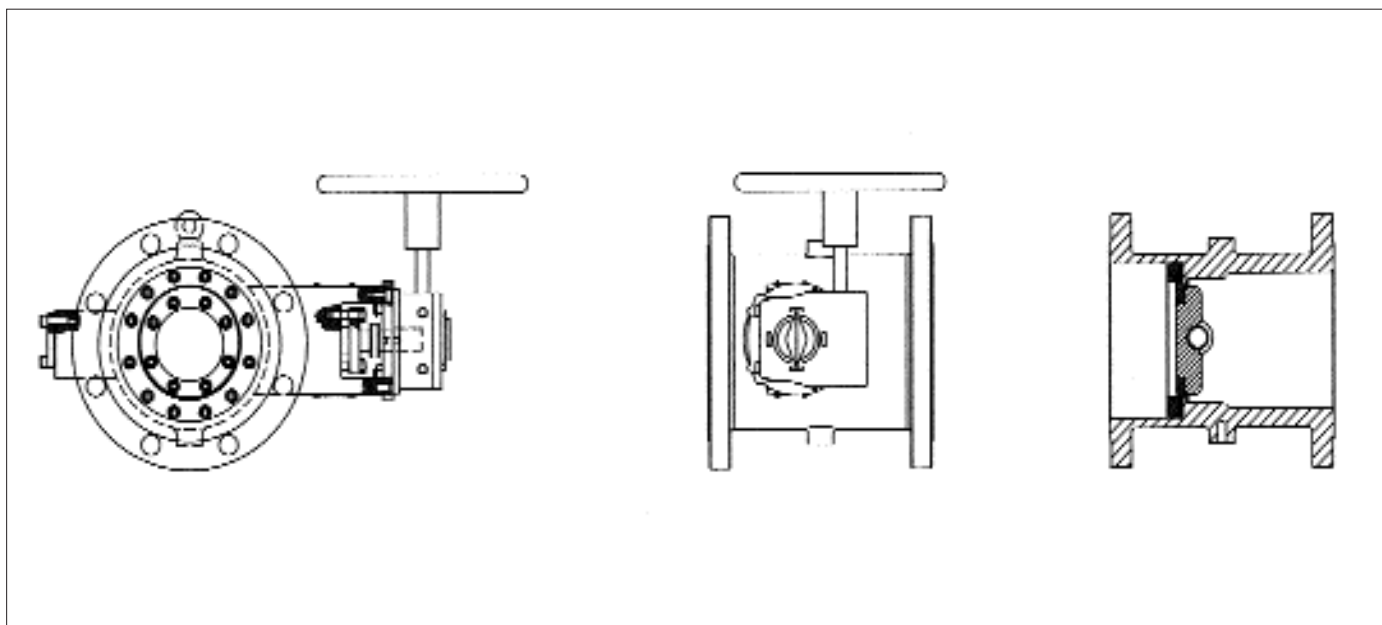

No	Description	Qty	No	Description	Qty
1	Body	1	17	Mounting Plate	1
2	Disc	1	18	Dowel Pin	2-4
3	Body Seat	1	19	Nameplate	1-2
4	Body Seat Retaining Ring	1	22	Disc Seal Screw	1set
5	Body Seat Gasket	1	23	Thrust Pad Screw	2-3
6	Disc Seal	1	24	Body Seat Screw	1set
7	Disc Seal Gasket	1	25	Mounting Plate Screw	4-6
8	Shaft	1	26	End Cover Screw	4
9	Shaft Pin	2-4	27	Gland Stud	2
10	Bearing	4	29	Gland Nut	2
11	Thrust Ring	1	33	Gland Packing	3
12	Thrust Pad	1	34	Gland Packing	2
13	End Cover	1	35	Key	1
14	End Cover Gasket	1	37	Anti-blowout Collar	1
15	Gland Plate	1	38	Set Screw Anti-blowout	1-2
16	Gland Plate Spigot	1			

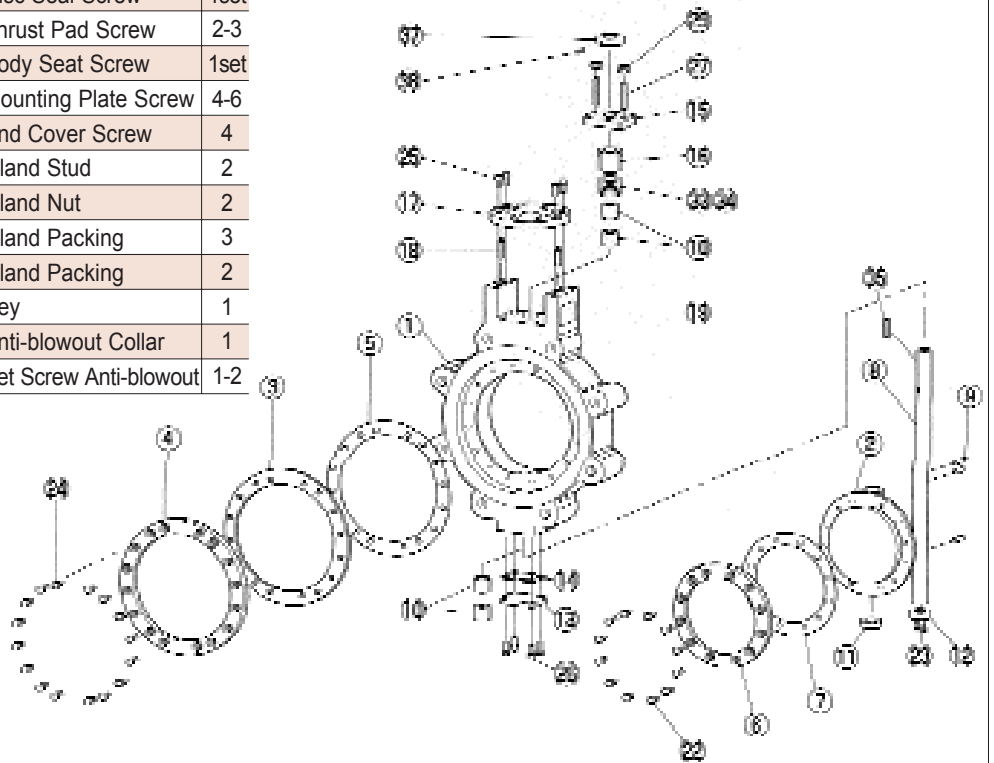

INTRODUCTION

This instruction provides general information on the operation, installation and maintenance of the Tritec triple offset valve. The Tritec valves have been designed and manufactured to operate in an aggressive environment under extremes of temperature and pressure for long periods and with minimal maintenance.

INSTRUCTIONS

PACKING

1. All valves will be despatched with protective covers attached to the flange faces to protect the gasket sealing surfaces and internal trim.
2. The valve disc is cracked off the seat in the almost closed position.
3. The Tritec nameplate shown in the picture contains information such as size, pressure class, materials and the unique serial number.

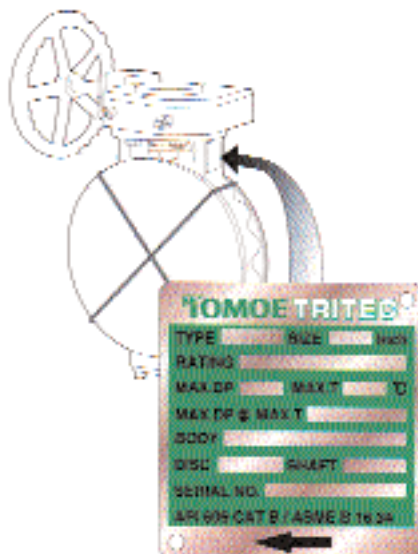

SPARE PARTS

1. When ordering spare parts or discussing matters concerning this valve with the sales office, it is essential to quote the unique Serial Number of the valve which is to be found on the stainless steel nameplate attached to the valve body adjacent to the operator.

TRANSPORTATION

1. Use crates or packing cases for ocean transportation.
2. For overland transportation, a covered vehicle is recommended with protective sheets covering the valves.

STORAGE

1. Store the valves indoors in a cool temperature between -10°C and $+60^{\circ}\text{C}$, humidity at 70% or less.
2. Do not remove the protective covers until ready to install valves.
3. Machined ferrous surfaces are protected with an approved rust preventative. For long periods of storage, apply the rust preventative once a year to the unpainted surfaces.
4. When storing valves unpacked, take care in protecting valves and actuators from excessive loads. Do not stack unpacked valves.
5. If the valve is for clean gas duty and is being supplied "DEGREASED", a label is attached stating this and the valve sealed in a polythene covering. It is suggested that the valve is kept packed until it is to be installed in the pipeline.

UNPACKING

1. Unpack valves just before installation.

INSTALLATION

- Ⓐ The valve is designed to seal against bidirectional flow and can therefore be installed with flow in either direction. However enhanced sealing life will be obtained with upstream flow against the shaft side of the disc. This preferred flow direction is shown on the nameplate attached to the valve body adjacent to the operator and also on the GA drawing. The valve may be installed in the pipeline with the valve shaft in a horizontal, vertical or intermediate position.
- Ⓑ Prior to installation, the pipeline must be cleaned from dirt and welding residues to avoid damage to the valve during operation.
- Ⓒ Ensure that the valve is closed prior to installation to avoid the risk of damage to the sealing surfaces.

- Ⓓ The valve must be lifted by the eyebolt or lifting eyes provided with the valve.
- Ⓔ The valve must not be lifted by the operator or handwheel.
- Ⓕ The valve must not be used for pipework alignment.
- Ⓖ The Lugged or Double flanged type valve is suitable for dead end service ie.end of line duty, in either direction (in case of the valve specified both directions) to the full rating pressure of the piping system.

MAINTENANCE

Tomoe Tritec triple offset valves are designed for minimum maintenance, however, it is recommended that the valve is cycled several times from fully open to fully closed every 3 months. In addition it is recommended that the valve is removed from the pipeline every two years and is subjected to a thorough visual inspection particularly in the sealing areas for signs of damage or wear.

To carry out maintenance as detailed below, no special tools are required but it should be noted that a torque wrench covering the torque range required will be needed. Before carrying out any of the maintenance detailed below, please ensure that a copy of the relevant GA drawing is available to facilitate identification and location of the component parts.

Adjustment / Replacement of Gland Packing

The Tomoe Tritec triple offset valve is supplied with a graphite adjustable gland packing which has been packed and adjusted for immediate use. However during service, leakage may occur and it may be necessary to tighten the Gland nut²⁹. This can be done with the operator on the valve. Do not overtighten the nuts however as this may cause damage to the valve and may lead to increased operating torque. If leakage persists then the Gland packings^{33,34} must be replaced and the following procedure followed:-

[Disassembly]

1. Remove the valve operator.
2. Remove the Mounting plate¹⁷.
3. Remove the Key³⁵ on the Shaft⁸.
4. Remove the Set screws anti-blowout³⁸ and slide the Anti-blowout collar³⁷ off the end of the Shaft⁸.
5. Remove the Gland plate¹⁵ and Gland plate spigot¹⁶ by undoing the Gland nuts²⁹ and sliding both parts off the end of the Shaft.
6. Extract the Gland packings^{33,34} using like a scribe. Do not reuse the Gland packings.

[Assembly]

1. Clean the gland packing hole of all dust and other foreign matters.
2. Insert a new packing set (Standard: both the braided outer rings and the plain inner rings) into the packing hole taking care when sliding the rings over the Shaft not to damage them on the keyway.
3. Replace the Gland plate¹⁵ and Gland plate spigot¹⁶ and tighten the Gland nuts²⁹ to the torque specified on the GA drawing. Do not overtighten as this will increase valve operating torques and may lead to damage to the valve.
4. Replace the Anti-blowout collar³⁷ and tighten the Set screws anti-blowout³⁸.
5. Replace the Mounting plate¹⁷ on the top of the Body¹ ensuring that the Dowel pins¹⁸ are refitted and that the Mounting plate screws²⁵ are secured to the torque specified on the GA drawing.
6. Replace the valve operator ensuring that the Dowel pins¹⁸ are refitted (if supplied) and tighten the fixings. Secure the Key³⁵ on the Shaft⁸.

Replacement of the Laminated Body Seat and/or Disc Seal

The Tomoe Tritec triple offset valve incorporates several innovative features which ensure long operating life and easy maintenance. The laminated Body seat³ and the Disc seal⁶ are readily field replaceable with no special tools meaning that both parts of sealing mechanism can be replaced without sending the valve back to the

factory. The Body seat³ and Disc seal⁶ are accurately machined on special fixtures so that they are not matched pairs and can be replaced either independently or as a pair.

Due to the triple offset geometry, the Body seat³ and Disc seal⁶ must be fitted into the valve with the correct radial alignment both relative to each other and relative the Shaft.

To facilitate this alignment, the Body seat³, Body seat retaining ring⁴, Disc seal⁶, Body¹ and Disc² all have an alignment arrow stamped on the component at 9 o'clock in the view of Disc side.

These components must be assembled with the alignment arrows in the same position. To aid initial alignment of these components and also correct alignment of the Body seat gasket⁵ and the Disc seal gasket⁷, the drillings are of an irregular spacing and can only be aligned in 1 orientation. It is essential to tighten the Body seat screws²⁴ and Disc seal screws²² to the torque detailed on the GA drawing.

[Disassembly]

1. The Disc² should be in the around 20° opened position.
2. Remove the Body seat screws²⁴.
3. Remove the Body seat retaining ring⁴, Body seat³ and Body seat gasket⁵.

If the Disc seal⁶ is to be replaced as a result of visual inspection,

- At this point, return the Disc² to the fully closed position.
- Remove Disc seal screws²² and then remove the Disc seal⁶ and the Disc seal gasket⁷.
- These works should be done in the Disc² upward position.

[Assembly]

1. Ensure that the Disc² is in a central float position by pushing the Disc² as far as possible towards the operator.
 - If the Disc seal⁶ was replaced as a result of visual inspection,
 - Ensure that the gasket sealing surface on the Disc² is clean and free from gasket debris etc.
 - Replacement of the Disc seal⁶ is the reverse of the above but it should be used the new Disc seal gasket⁷.
 - This assembly should be done in the Disc² upward position.
 - The correct radial alignment of these components is achieved using the alignment arrows.
 - Tighten the Disc seal screws²² to the torque as detailed on the GA drawing.
2. Ensure that the gasket sealing surface in the Body¹ is clean and free from gasket debris etc.
3. Replacement of the Body seat³ is the reverse of the disassembly described above, but it should be used the new Body seat gasket⁵.
4. The valve should be in the Disc² upward position and in the around 20° opened position.
5. Replace the new Body seat gasket⁵ with correct alignment. Apply a light smear of graphite grease to the topside of the Body seat³ and the underside of the Seat retaining ring⁴ and then replace these components.
6. To ensure correct positioning of the Body seat³, the Body seat screws²⁴ should be lightly tightened only, which is a load to feel a slight tension through the screw. Close the Disc² lightly and then open again.
7. Tighten the Body seat screws²⁴ to about 50% torque of specified on the GA drawing. At this stage close the Disc using the operator so that the valve is fully closed and the Disc² seal⁶ is firmly located against the Body seat³.
8. Ensure that the gap between the Disc² and the Thrust ring¹¹ is within the tolerance specified on the GA drawing.
9. Tighten the Body seat screws²⁴ to the correct torque as detailed on the GA drawing.

Your local agent/distributor:

TOMOE TRITEC, LTD.

Cleanwater Road, Queensway Meadows Ind. Est. Newport, Gwent NP19 4ST United Kingdom
Telephone: 44-1633-292601 Teletax: 44-1633-292605 www.tritecvalve.com www.tomoetrtec.com

• International Department

TOMOE VALVE CO., LTD.

11th Floor, Mitsui Bldg., 1-11-7 Utsubo Hommachi, Nishi-ku, Osaka550-0004, Japan
Telephone: 81-6-448-4320 Teletax: 81-6-448-4330

• Singapore Operation

TOMOE VALVE S.E.A.PTE. LTD.

28 Third Lok
Yang Road, Singapore 628 016
Telephone: (0) 665-8995060 Teletax: (0) 665-8995061

All rights reserved. No part of this catalog may be reproduced without the permission of the Publisher.